

REV.	DESCRIPTION	DATE	APPROVED
------	-------------	------	----------

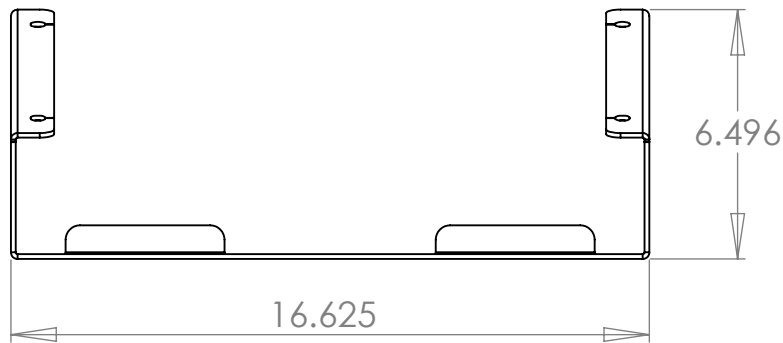
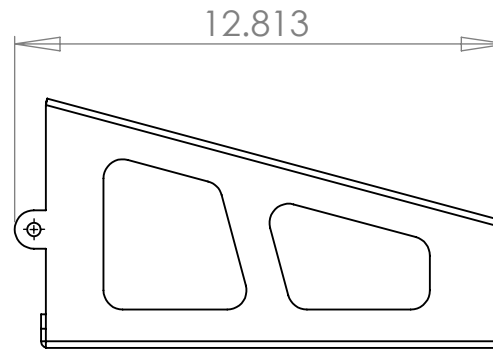
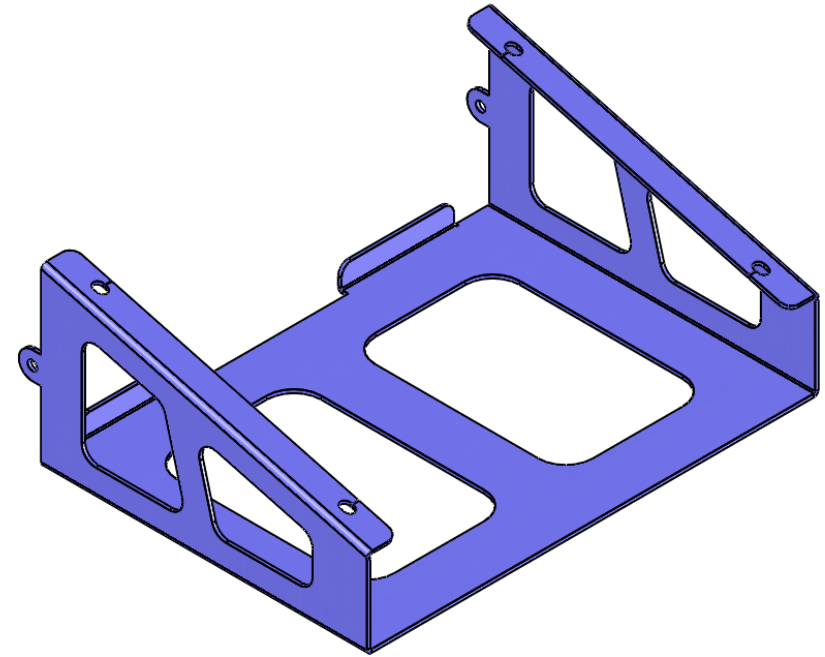

DRAWN BY: KLH DRAWN DATE: 4/9/2014 UNLESS OTHERWISE SPECIFIED: DIMENSIONS ARE IN INCHES TOLERANCES: FRACTIONAL $\pm 1/16"$ ANGULAR: MACH $\pm 0.25^\circ$ BEND $\pm 1.5^\circ$ TWO PLACE DECIMAL $\pm 0.020"$ THREE PLACE DECIMAL $\pm 0.005"$ MATERIAL: 1/8" 5052 Al DO NOT SCALE DRAWING	<b>Inventive LLC</b> In The Ditch Towing Products DESCRIPTION: <b>Steel Scotch Underbody Mount</b> SIZE PART NO. <b>A</b> ITD6714-01 SHEET SCALE 1:5	REV SHEET 1 of 1
--	--	---------------------