

| REV. | DESCRIPTION | DATE | APPROVED |
|------|-------------|------|----------|
|------|-------------|------|----------|

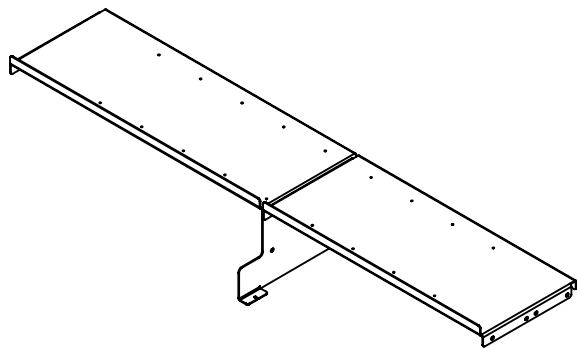
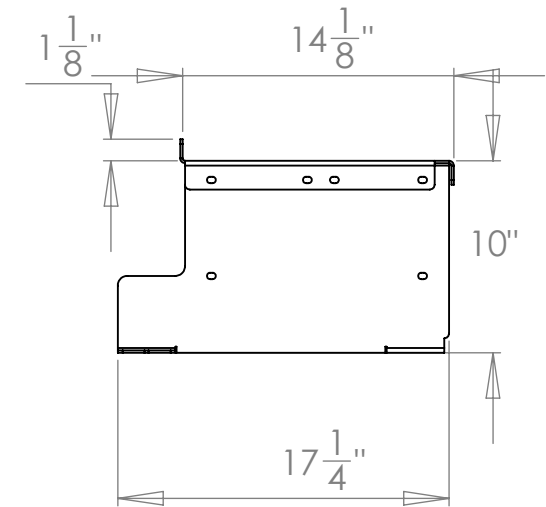
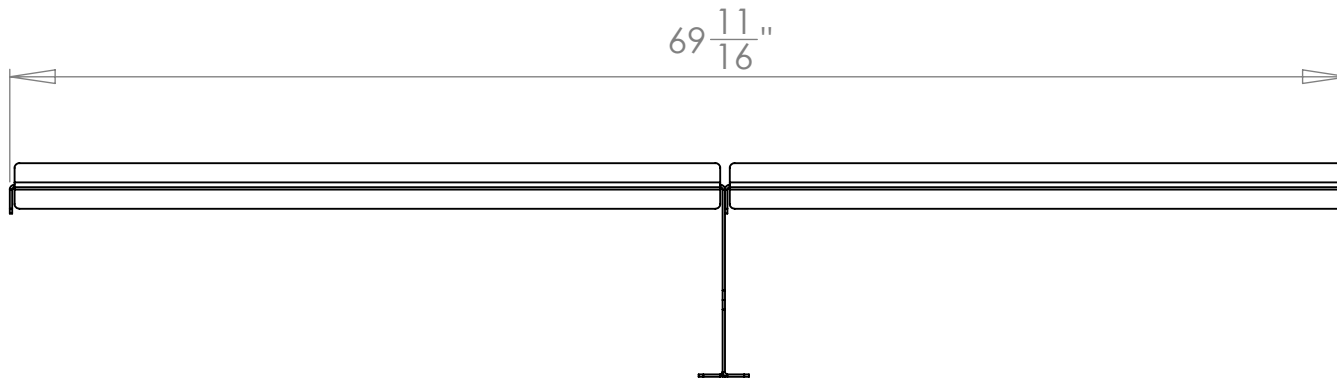

DRAWN BY: KBH DRAWN DATE: 7/31/2012

UNLESS OTHERWISE SPECIFIED:

DIMENSIONS ARE IN INCHES

TOLERANCES:

FRACTIONAL $\pm 1/16$ "

ANGULAR: MACH $\pm 0.25^\circ$ BEND $\pm 1.5^\circ$

TWO PLACE DECIMAL ± 0.020 "

THREE PLACE DECIMAL ± 0.005 "

MATERIAL: See BOM

DO NOT SCALE DRAWING

Inventive LLC
In The Ditch Towing Products

PART NAME
70" Shelf Kit

SIZE PART NO.
A ITD1286

SHEET SCALE 1:20 SHEET 1 of 1